

Der große Wurf:
Architekturdekoration und Schauspiel
in Berninis Sant'Andrea al Quirinale in Rom

Dr. Martin Raspe
Bibliotheca Hertziana, Rom

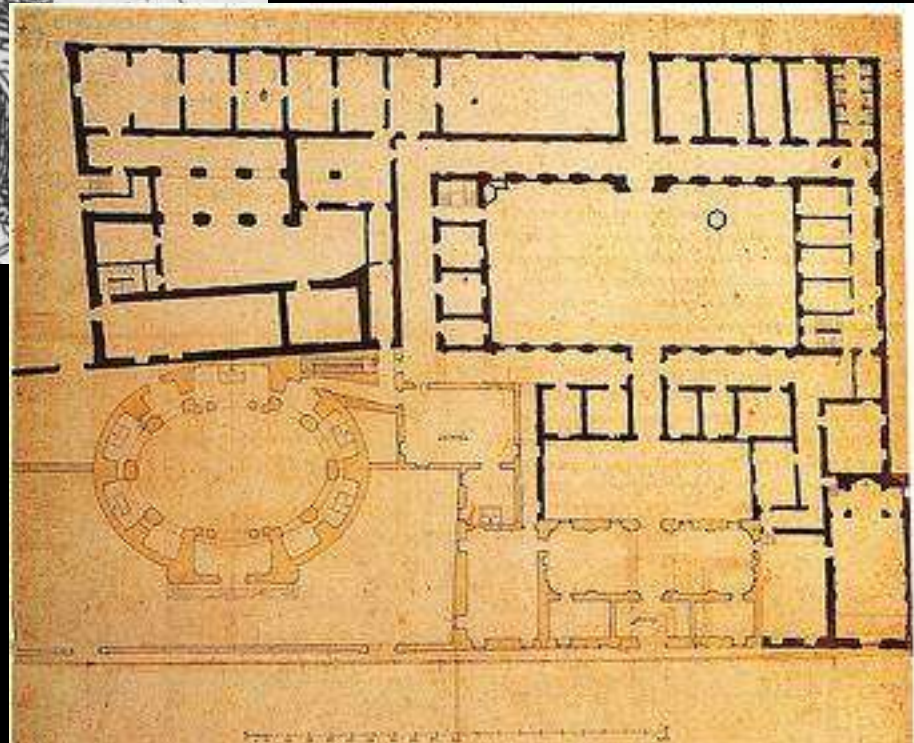

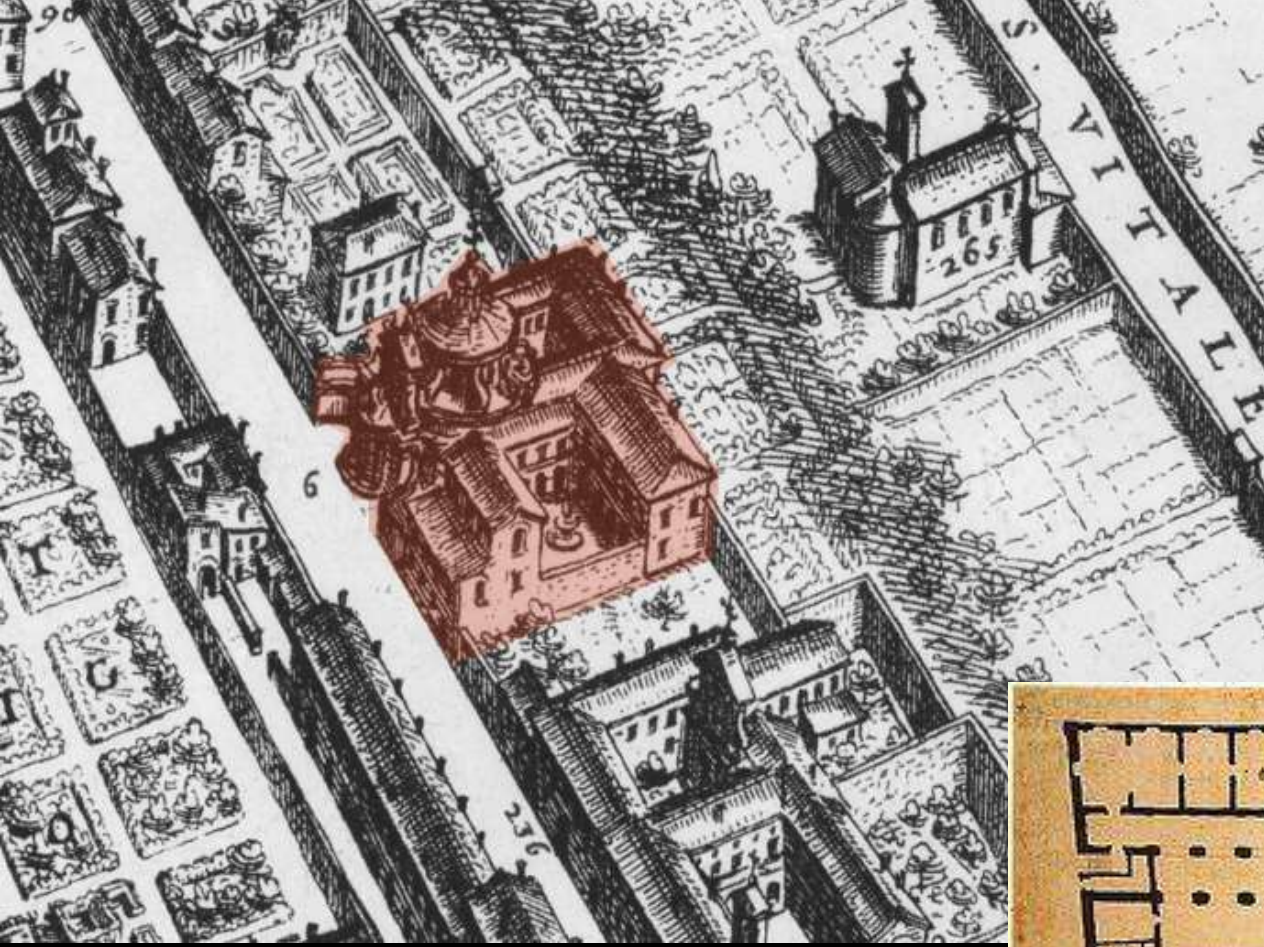

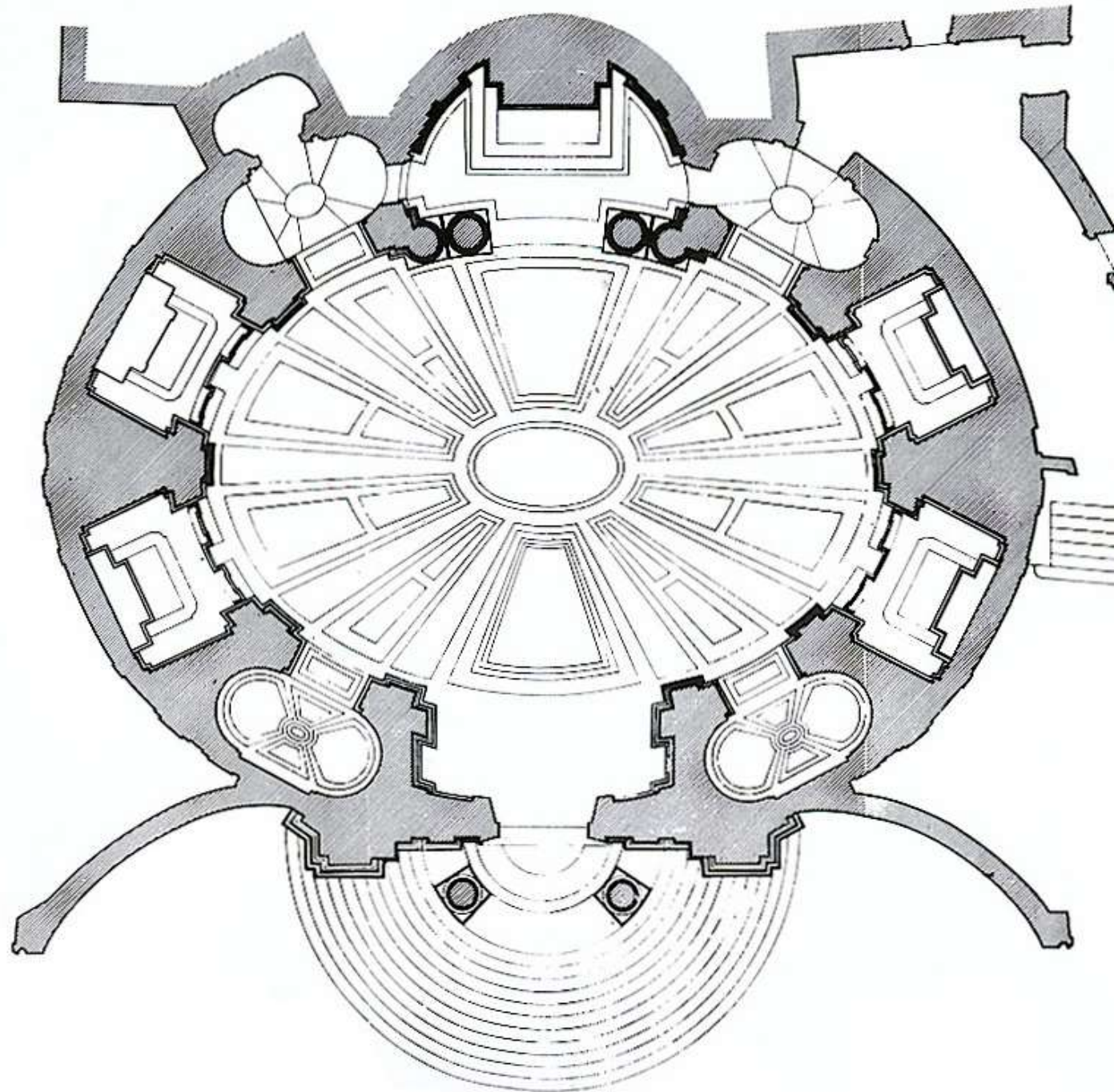



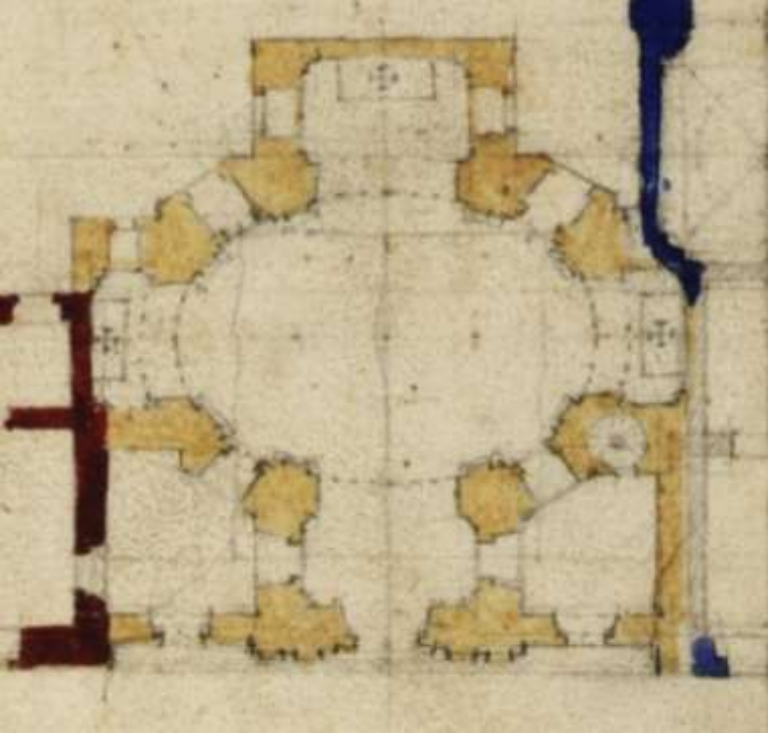

Francesco Borromini
Grundriß der Bernini-Kapelle
im Collegio di Propaganda Fide
Wien, Albertina, Az Rom 887 (Ausschnitt)



Francesco Rosselli
Weltkarte, 1508



Rom, St. Peter, Baldachin, Blick von unten

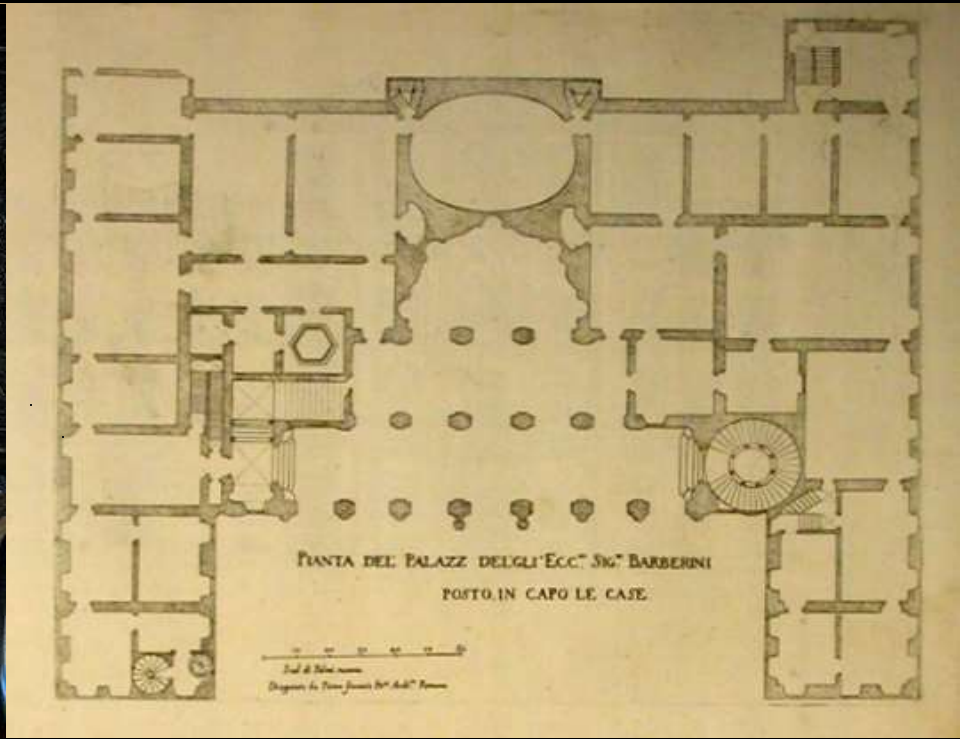

Rom, Palazzo Barberini, Grundriß

Varese, Sacro Monte, 3.a cappella
(1605/08)

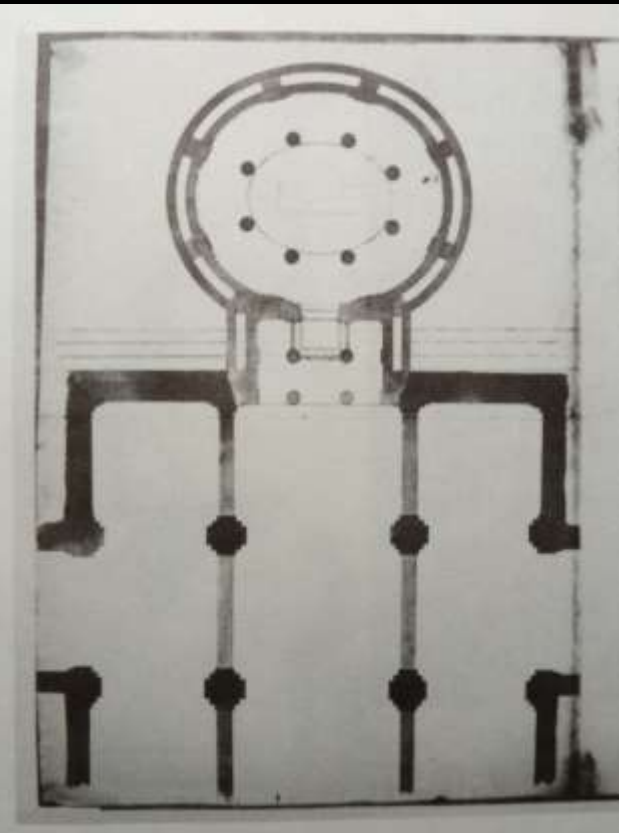

Francesco Maria Ricchini
Entwurf für den Scurolo Nuovo
im Dom zu Mailand (1606)

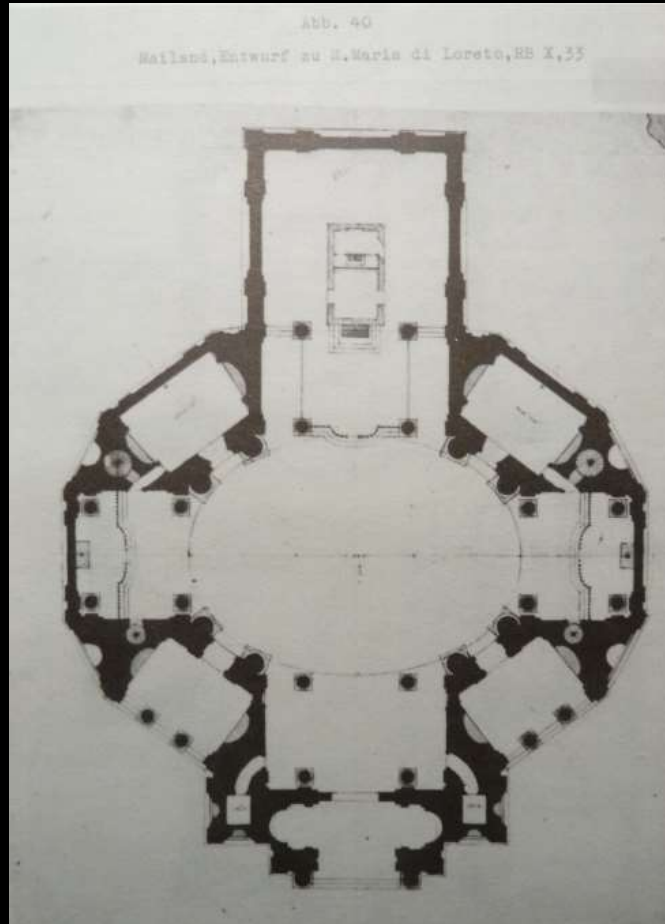

Francesco Maria Ricchini
Entwurf für S. Maria di Loreto
in Mailand (um 1610)

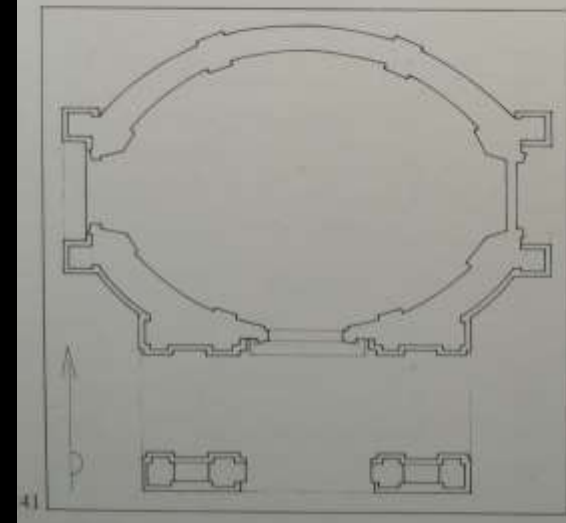
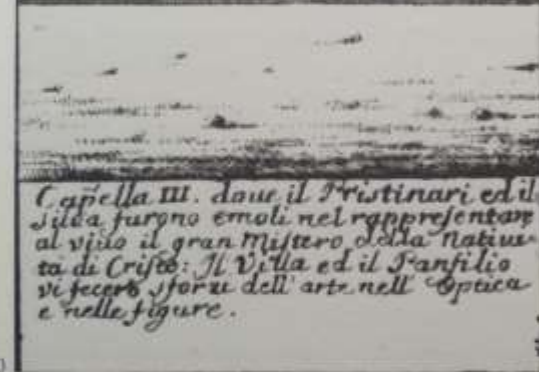

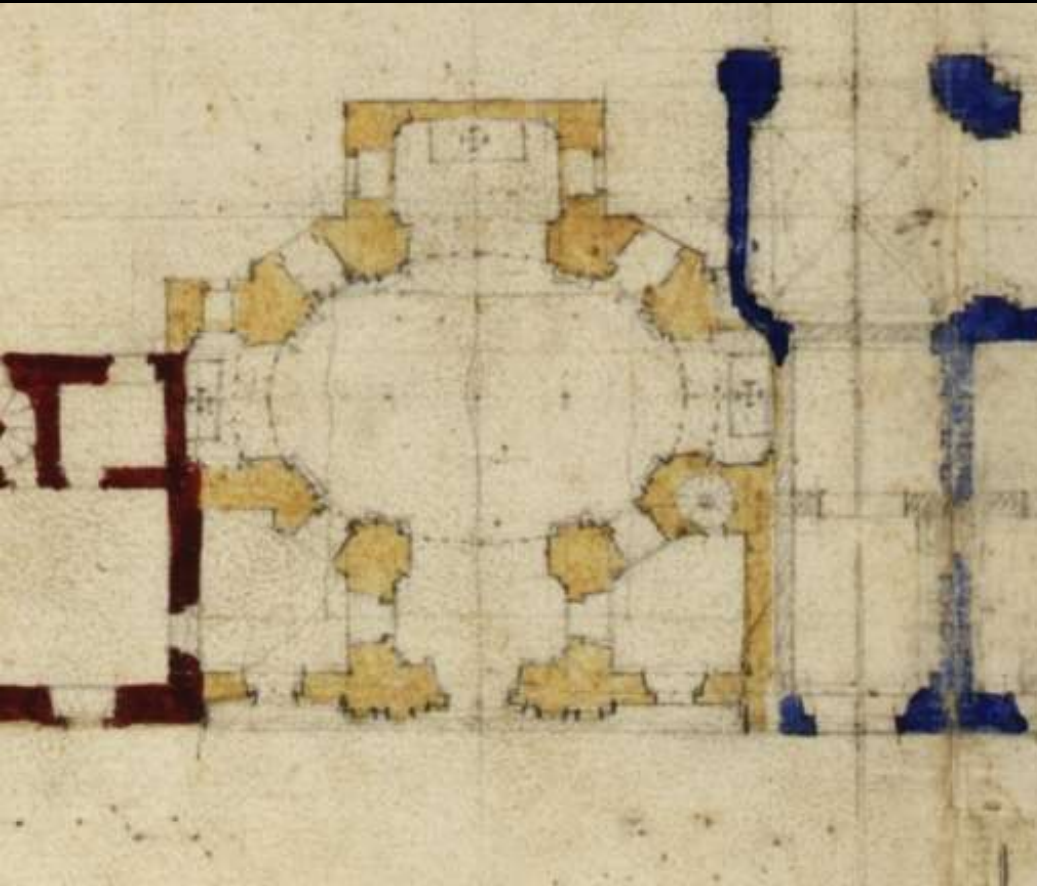

Francesco Borromini
Grundriß und Fassadenaufriß der Bernini-Kapelle im Collegio di Propaganda Fide
Wien, Albertina, Az Rom 887 (Ausschnitt) und Az Rom 147





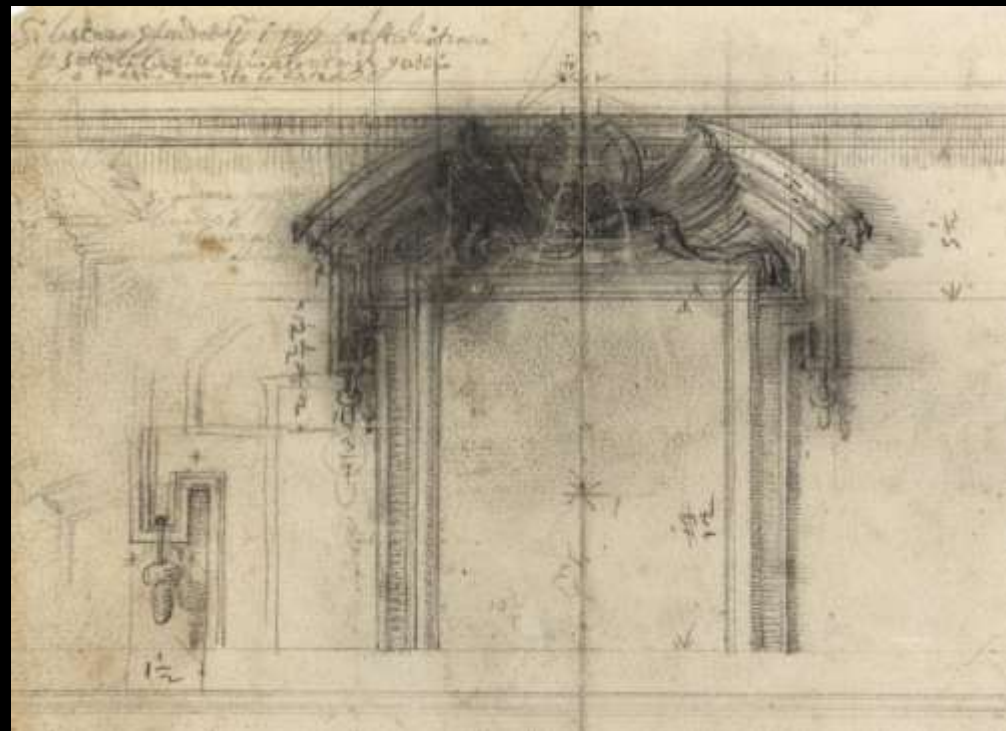

Francesco Borromini
Entwurf für die Fenster im 2. OG
des Collegio di Propaganda Fide in Rom
Wien, Albertina, Az Rom 918



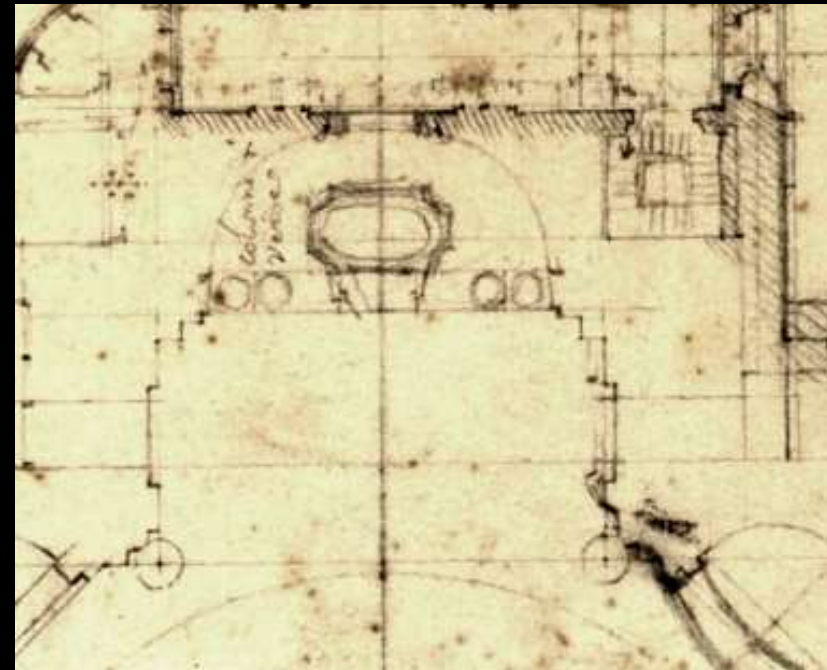
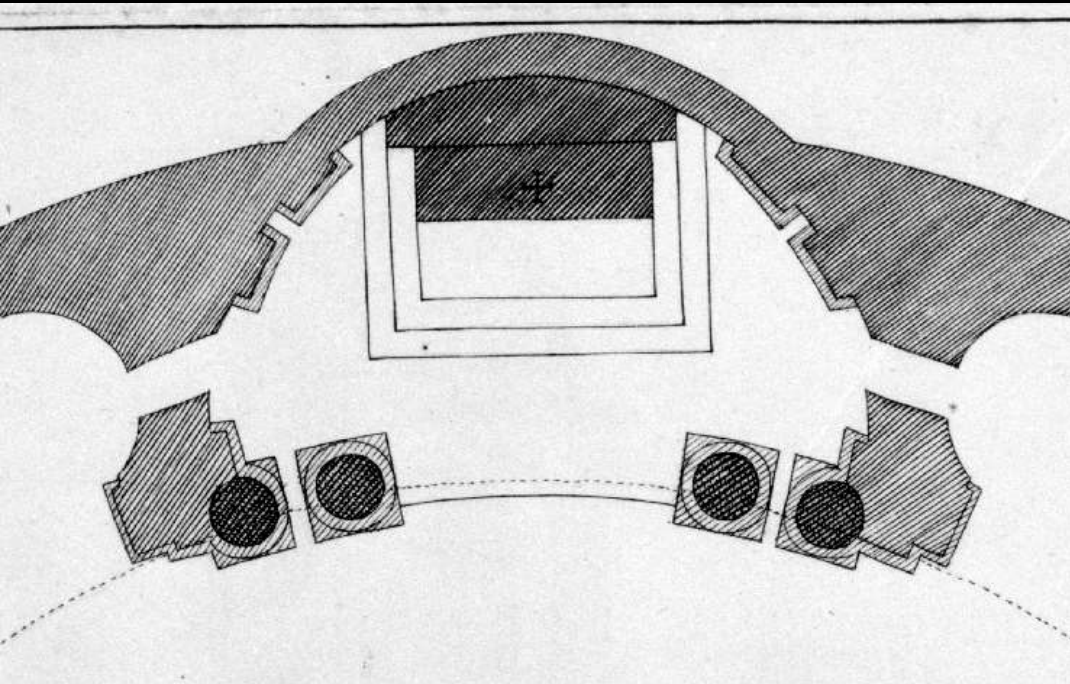

Francesco Borromini
Entwurf für die Grabkapelle
für Papst Innozenz X. Pamphili
in S. Agnese in Agone in Rom
Wien, Albertina, Az Rom 55 (Ausschnitt)

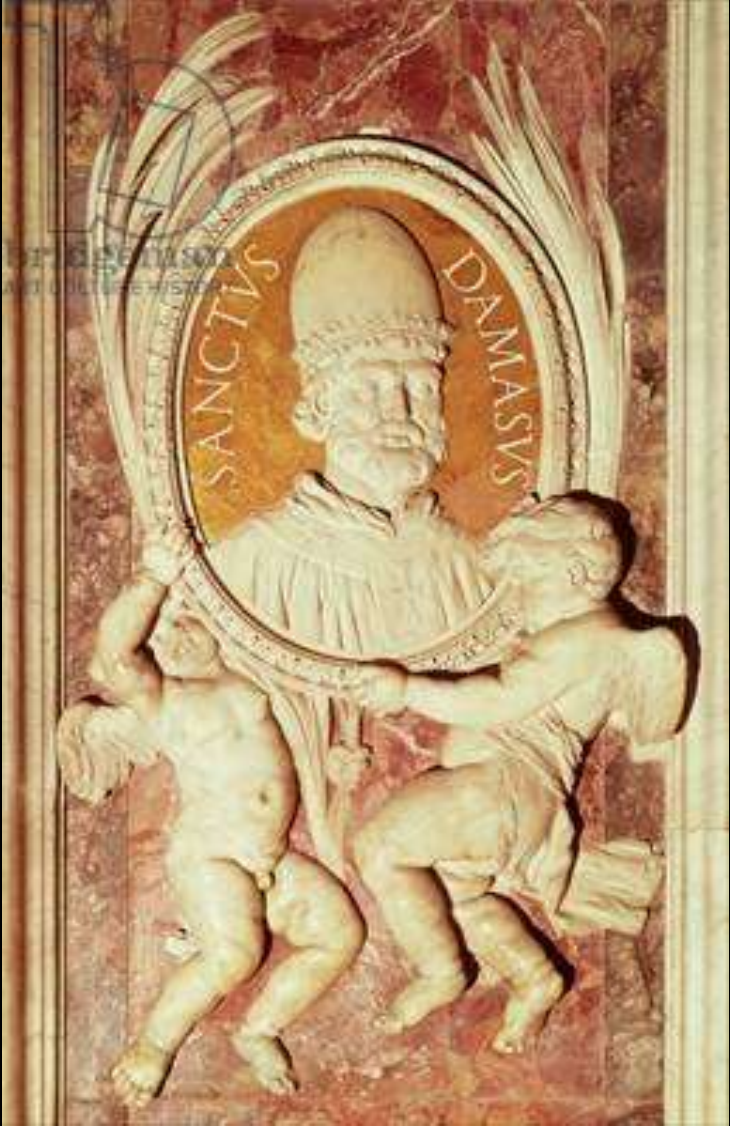

Rom, Sankt Peter
Marmorverkleidung des Langhauses
(Detail), 1650



Rom, Sant'Agnese in Agone
Marmorverkleidung, ab 1653





DIVO ANDREAE APOSTOLO
CAMILIVS PRINCEPS PAMPHILIVS
INNOCENTII X FRATRIS FILIVS
A FVNDAMENTIS EXTRVXIT















Cuerda de mano

Sistema de cuerdas interiores
para un cierre completo de la atarraya

Malla o agujero de red

www.redtarraya.com

Cuerda interior

Plomos

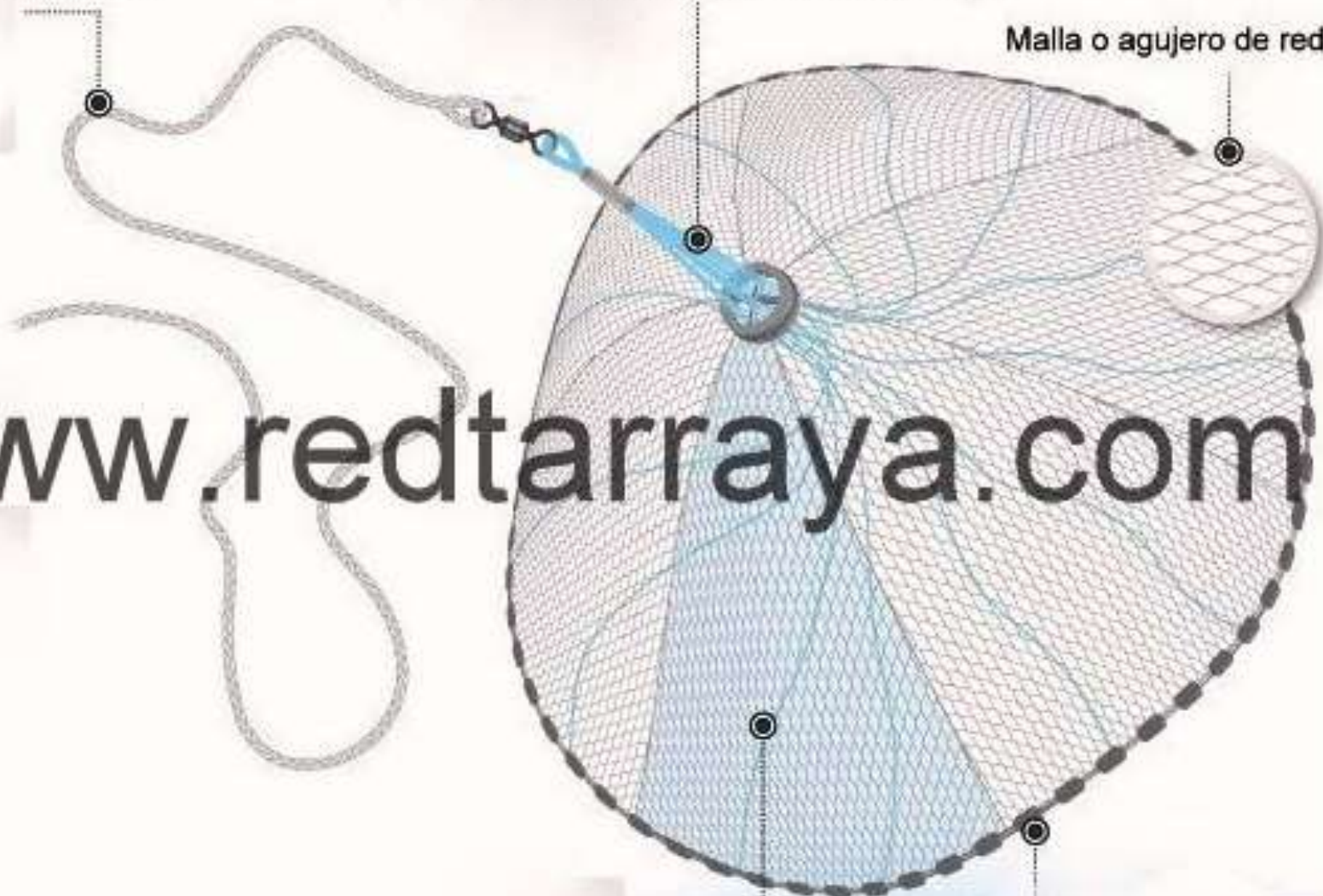









'Si quando intumuit Arno spumantibus undis, Sic agitant cymbas, piscantur rete rotundo.'

Giovanni Stradano, Fischfang auf dem Arno, Kupferstich



Alter Fischer
Rom, Musei Vaticani
ehem. Sammlung Pamphili





NAV MACHIA

Idest Navalis pugna ex uelocitate lapidum et numeru
Sub colle Hortulorum nimirum sub

DOMITIANI

monumentis graphica deformatio
Monte Sancti Trinitatis.

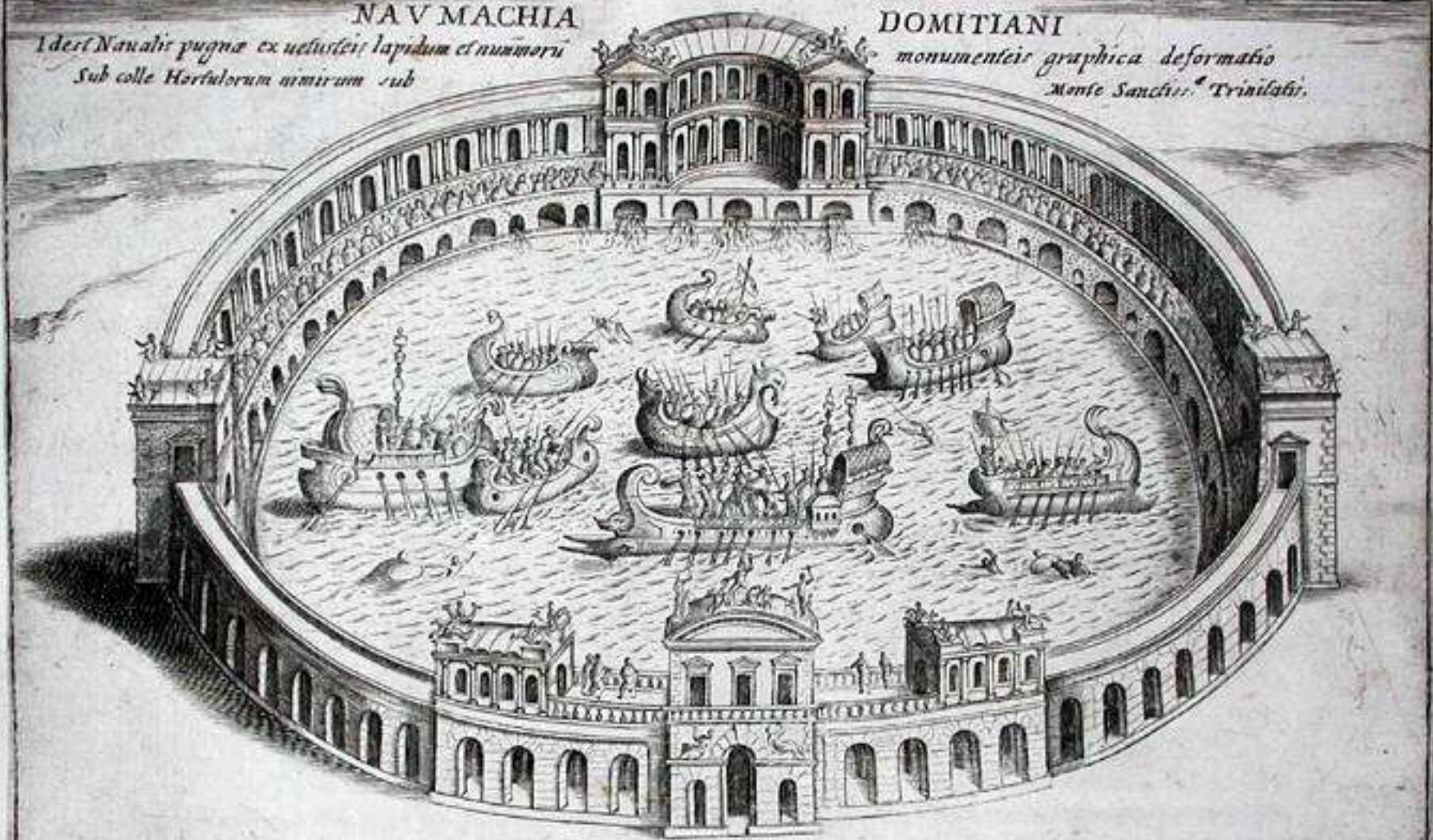

Naumachia ita dicta a praelio navali ad exercenda enim iuventute Romanâ nō solum terrestri, sed etiâ navali praelio Naumachia instruebatur, quod nō minus clas-
sica caeteris Romanis prerogaretur imperiis. Hanc Domitianus Imp. extruxit sub colle hortulorum, loco sane comodo, quod facile in valle hanc Martia dicebatur pe-
terant aqua per aquas, ducuntur ex locis editoribus deduci. Effusa enim terra undique muro circumscripta, in qua ex aqueductibus emissa aqua lacu ma-
pelagus efficiebat latissimus ita ut navibus ac turribus eius loci ualde comodo tali enim artificio nunc educeretur aqua nunc reducebatur finito praelio ut
ubi modo pelagus, nunc tellus uideretur, cum peregre aduentantibus praeter spem atque oblectationem. Adhuc superius nō nulla uestigia ex quibus aliquis
modo colligitur qualis fuerit eius magnitudo, nō desunt qui uolunt ad Tiberim ferme excurrisse nauibus enim hic turrimus instar naualis, ut dicit, comitibus autem
praelia nō minore spectatui uoluptate qua ea gererentur utilitate, eo modo in Circus et Amphitheatris terrestria praelia iudicantur. Ex his enim exercitiis omnibus ille fructus con-
stabat ut et otium pelleretur ex Urbe, populus teneretur, et Rom. praeterim iuuentutis ab illegato otio assuesceret praelio, quibus Romani propaganda et tuenda erant imperia committenda.





1. Palazzo Apostolico di S. Pietro
e S. Paolo con piazza di S. Pietro.

2. Museo del Palazzo Apostolico
di S. Pietro e S. Paolo.

Veduta dell'insigne Basilica Vaticana, dell'ampio Portico, e Piazza adiacente

3. Palazzo Apostolico di S. Pietro
e S. Paolo con piazza di S. Pietro.

4. Palazzo Apostolico di S. Pietro
e S. Paolo con piazza di S. Pietro.





